

MASTER EXCAVATOR

MT220-8LC

- OPERATING WEIGHT
24000kg
- BUCKET CAPACITY
0.4m³
- RATED POWER
115Kw
- ENGINE BRAND : MASTER
4 STROKE 6 CYLINDER WATER COOLED
5400 CC. DISPLACEMENT
- HYDRAULIC TRANSMISSION
TRIPLE GROUSER TRACK DRIVEN INDEPENDENTLY
STEEL BUCKET WITH SIDE CUTTER
- DRAWBAR PULL
210 KN



TECHNICAL SPECIFICATIONS

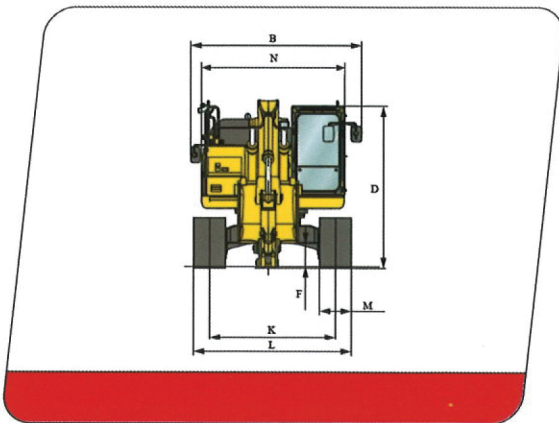
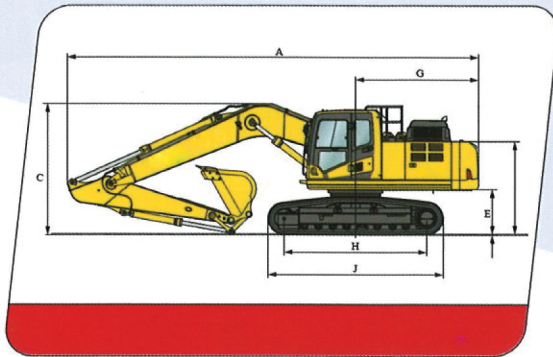

PERFORMANCE PARAMETERS

MODEL	UNIT	MT220-8LC
OPERATING WEIGHT	Ton	24
BUCKET CAPACITY	m ³	0.4
ENGINE BRAND		MASTER
RATED POWER	kw/r/min	115/2200
HYDRAULIC TANK CAPACITY L		160
TRAVEL SPEED	km/h	5/3.1
SWING SPEED	r/min	10
MAX. CLIMBING DEGREE		70%
GROUNDING PRESSURE	Kpa	45.6
BUCKET DIGGING FORCE ISO	Mpa	70
ARM LENGTH	mm	7.85
BOOM LENGTH	mm	9.65

MACHINE DIMENSIONS

UNIT : mm

A	OVERAIL LENGTH	14000
B	OVERAIL WIDTH	3390
C	OVERAIL HEIGHT (BOOM TOP)	3310
D	OVERAIL HEIGHT (CAB TOP)	3010
E	COUNTERWEIGHT GROUND CLEARANCE	1080
G	TAIL SWING RADIUS	3130
H	TRACK GROUND LENGTH	3840
J	TRACK GROUND LENGTH	4660
K	TRACK GAUGE	2580
L	TRACK WIDTH	3390
M	TRACK SHOE WIDTH	800

OPERATING RANGE

UNIT : mm

O	O-MAX. DIGGING HEIGHT	15800
P	P-MAX. DUMPING HEIGHT	13000
Q	Q-MAX. DIGGING DEPTH	13300
R	R-MAX. VERTICAL WALL DIGGING DEPTH	13100
T	T-MAX. DIGGING REACH	18200
V	V-MIN. SWING RADIUS	5330
W	W-MAX. HEIGHT AT MIN. SWING RADIUS	5330

*MATERIALS AND SPECIFICATION ARE SUBJECT TO CHANGE WITHOUT NOTICE

STANDARD CONFIGURATION

AIR CONDITIONER	RADIO
SUSPENSION SEAT	RANDOM TOOLS
RUBBER SHOCK ABSORBER	AUTOMATIC IDLE SYSTEM
500mm TRACK SHOES/500mm	COLOR DISPLAY SCREEN

OPTIONAL CONFIGURATION

OPTIONAL LONG ARM	WIDENED TRACK SHOES
FOPS/ROPS CAB	OPERATOR CAB GUARD
ELECTRIC FUEL PUMP SYSTEM	
HAMMER, GRAPPLE ETC. SPECIAL ATTACHMENT	

MASTER IMTACT CO.,LTD.

22/24 Moo 15, Rachadaewa, Bangplee, Samutprakarn

MADE IN THAILAND